

Schéma 1



Schéma 2

Ø	B	#
111	134 => 181	800 030
125	134 => 181	562 005
200	134 => 181	562 078
251	134 => 181	800 491
252	134 => 181	590 061
253	134 => 181	590 060
254	134 => 181	590 074
258	134 => 181	531 020
260	134 => 181	800 426
261	134 => 181	542 008

116	600 W	561 002
	700 W	561 031
	850 W	561 032

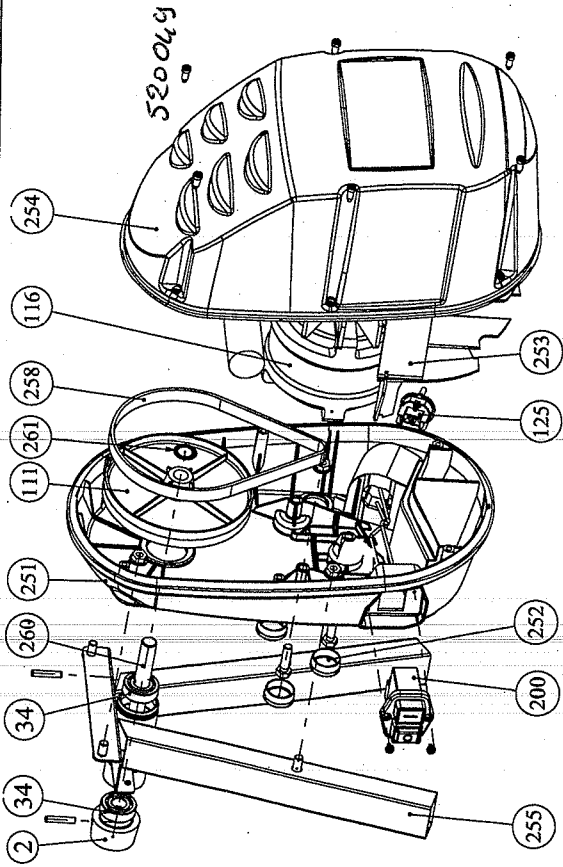
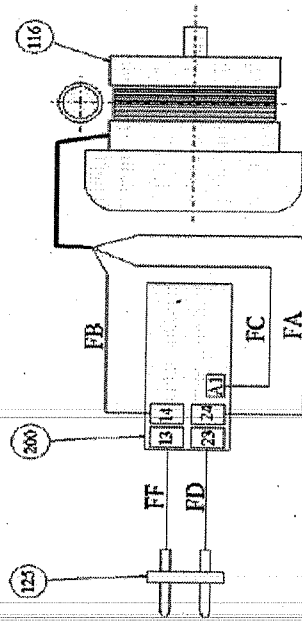

Bloc moteur et capot IP44  
Depuis 2002

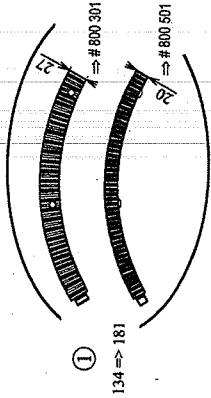

Ø	B	#
2	134 => 181	800 007
3	134 => 164	800 093
	181	800 254
3-4	134 => 181	590 002
3-5	134 => 181	543 011
255	134 => 154	800 329
	184	800 330
	181	800 331
5	134 => 164	800 102
	181	800 103
6	134	800 095
	154	800 096
	164 => 181	800 097
9	164 => 181	537 002
13	134 => 154	800 098
256	164 => 181	800 332
257	164 => 181	800 333
15	164 => 181	515 000
19	134 => 154	800 176
	164 => 181	800 177
20	164 => 181	537 510

Code 501 = [29 + 30 + 31 + 32]  
Code 502 = [30 + 31 + 32]

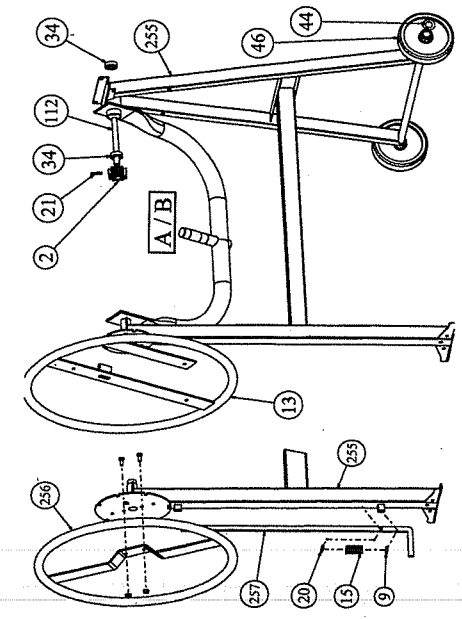

Schéma 3